

# HydraMAX<sup>®</sup> Trailer Pump -316 x1

Little Size, BIG Capacity



**UNITAMA**  
Hydromechanical Solutions

**MWI**  
PUMPS

## APPLICATIONS:

Flood Control

Industrial

Bypass Pumping

Stormwater Drainage

Construction Dewatering

Agriculture

Aquaculture

Quarries

**550 Lps**



## FEATURES

### Diesel Engine Drive Unit

- Trailer mounted of Power unit
- Trailer mounted unit available with fenders, light kit for trailer and (optional) braking system
- Engine and hydraulic safety shutdowns
- Complete Hydraulic System with control panel, pump, filters, tank and gauges
- Small hydraulic tank reduces fluid replacement costs
- Reliable, efficient Vane Hydraulic Pump
- Environmentally friendly - inherently biodegradable hydraulic fluid

### Hydraflo™ - HAC 316

- Open 3 bladed axial impeller for handling trash and sewage
- Easily passes 3 1/8" solids
- Runs dry indefinitely
- Oil lubricated seals and bearings
- Reliable, rugged Vane Hydraulic Motor
- Replaceable wear plates
- Installable at any angle
- Hydraflo is a **lightweight** pump, approx 265Kg for HAC316 size
- It is a simple, straightforward design that requires very little maintenance



### 10% Increased pump efficiency

Direct Drive Design<sup>®</sup> combined with improved hydraulic pump characteristics results in better suction capabilities, more flow and lower fuel consumption.

### Package Flexibility Suspension

Independent wheel action  
Soft, quiet  
Smoother ride and longer life  
Progressive torque  
Safer and stronger  
Easy replacement  
Quick installation

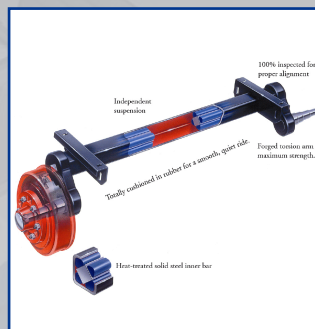

### DriveOn<sup>®</sup>

- 2,000 hour service interval.
- 65% less scheduled maintenance.
- 25% savings on engine oil.
- Ideal physical working conditions during maintenance.

### Hydraflo™ Pump Advantage

Versatility  
Fast Installation  
Designed for Longer Life  
Less Submergence Required  
Variable speed pumping



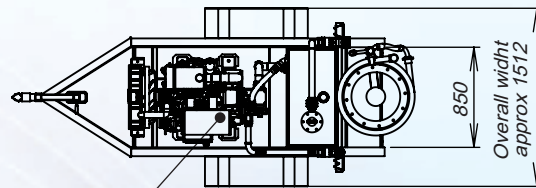
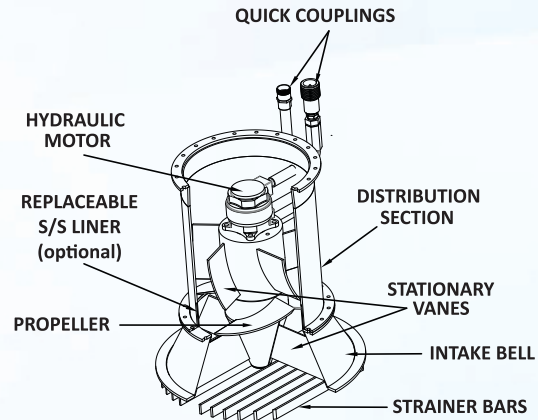

Diesel Dive Unit

Hydraflo Pump

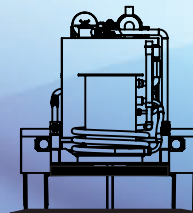
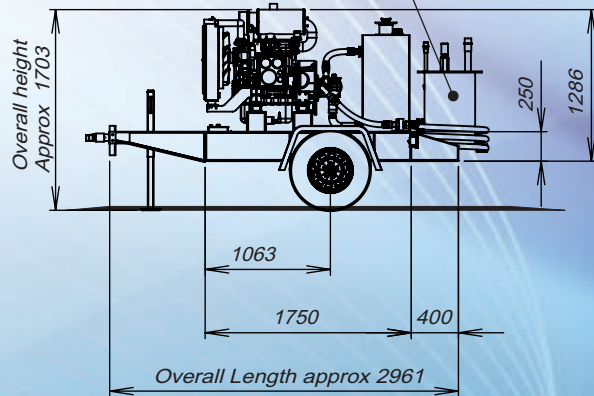
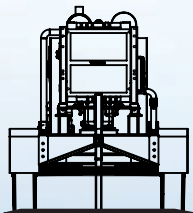

## PERFORMANCE

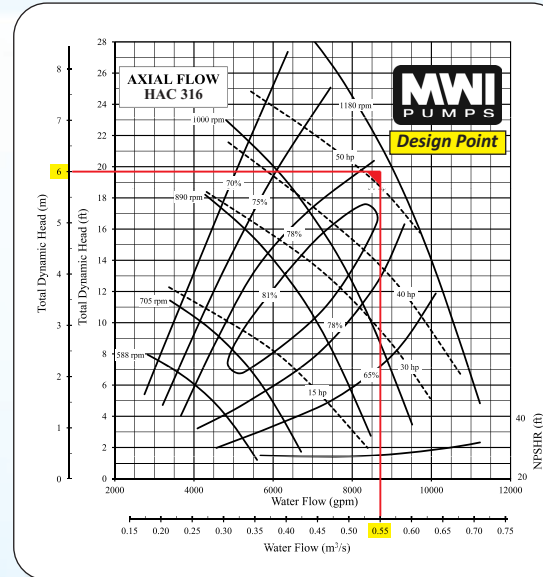

## AVAILABLE WITH ELECTRIC DRIVE UNIT

## MATERIALS & SPECIFICATIONS

### HYDRAFLO PUMP

- Heavy Duty Hydraulic Motor Type
- Impeller - 3 bladed axial - A36 Stainless Steel
- Shaft material - 300 series stainless steel
- High strength pump
- Wear plates - A36 steel - upper and lower
- Discharge 16" ANSI Pattern Flange
- Hydraulic quick disconnects
- Mechanical seal - Silicone carbide - Hydraulic-fluid bathed
- Bearings - Hydraulic-fluid lubricated-50,000 hours - Minimum life.
- Lightweight pump - approx 265 kg
- Coating - MoTar Standard - Epoxy optional

### DIESEL Drive Unit

- Diesel engine 80HP / 55kW
- Engine panel with tach, hour meter, high coolant temperature and low oil pressure shutdowns plus over speed protection.
- Approx 200 Liter vented fuel tank with extra large filler and fuel gauge.
- 288 Liter hydraulic fluid tank
- Safety shutdowns for low hydraulic oil, excessive vacuum and high hydraulic oil temperature.
- Equipped with an internal suction strainer, return filter, external sight gauge for hydraulic oil and vented hydraulic oil filler cap.
- Hydraulic pump - Vane type
- Lightweight - skid Frame

