

HydraMAX[®] Trailer Pump -324 x1

Little Size, BIG Capacity



UNITAMA
Hydromechanical Solutions

MWI
PUMPS

APPLICATIONS:

Flood Control

Industrial

Bypass Pumping

Stormwater Drainage

Construction Dewatering

Agriculture

Aquaculture

Quarries

1200 Lps



FEATURES

Diesel Engine Drive Unit

- Trailer mounted of Power unit
- Trailer mounted unit available with fenders, light kit for trailer and (optional) braking system
- Engine and hydraulic safety shutdowns
- Complete Hydraulic System with control panel, pump, filters, tank and gauges
- Small hydraulic tank reduces fluid replacement costs
- Reliable, efficient Vane Hydraulic Pump
- Environmentally friendly - inherently biodegradable hydraulic fluid

Hydraflo™ - HAC 324

- Open 3 bladed axial impeller for handling trash and sewage
- Easily passes 3 1/8" solids
- Runs dry indefinitely
- Oil lubricated seals and bearings
- Reliable, rugged Vane Hydraulic Motor
- Replaceable wear plates
- Installable at any angle
- Hydraflo is a **lightweight** pump, approx 680Kg for HAC324 size
- It is a simple, straightforward design that requires very little maintenance



10% Increased pump efficiency

Direct Drive Design[®] combined with improved hydraulic pump characteristics results in better suction capabilities, more flow and lower fuel consumption.

Package Flexibility Suspension

Independent wheel action
Soft, quiet
Smoother ride and longer life
Progressive torque
Safer and stronger
Easy replacement
Quick installation

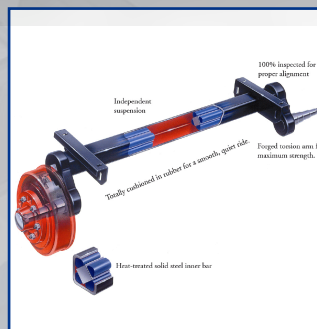

DriveOn[®]

- 2,000 hour service interval.
- 65% less scheduled maintenance.
- 25% savings on engine oil.
- Ideal physical working conditions during maintenance.

Hydraflo™ Pump Advantage

Versatility
Fast Installation
Designed for Longer Life
Less Submergence Required
Variable speed pumping



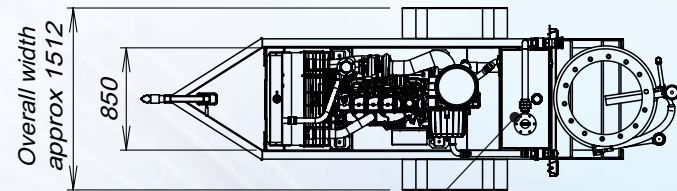
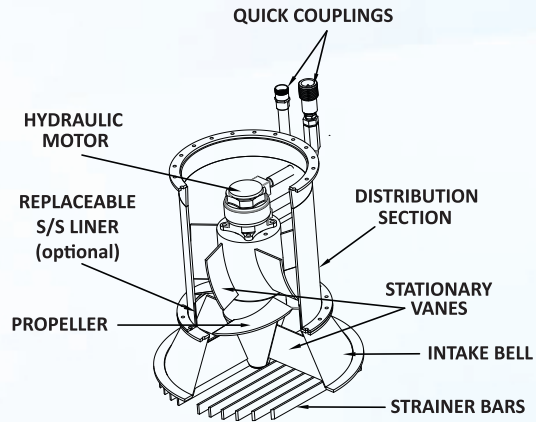

Diesel Drive Unit

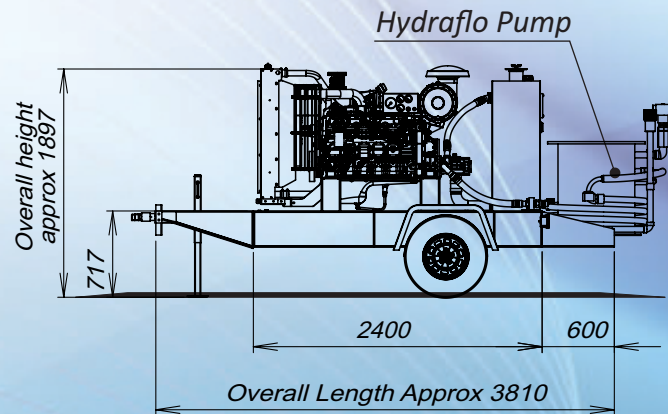
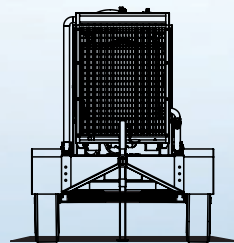

Hydraflo Pump

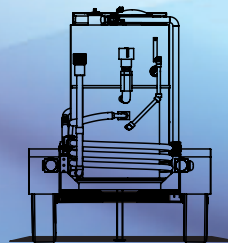

PERFORMANCE

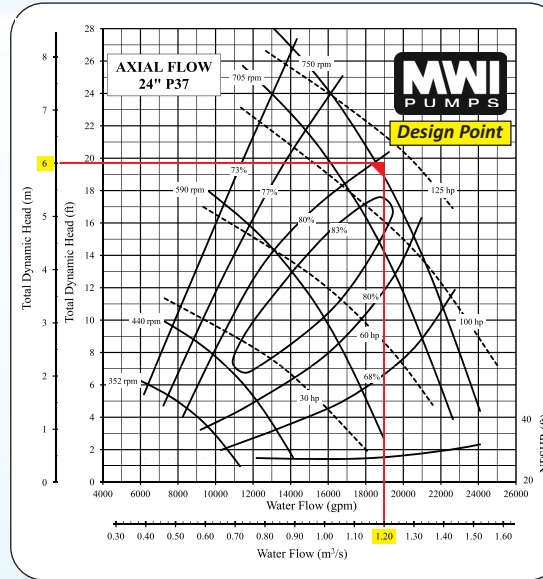

MATERIALS & SPECIFICATIONS

- HYDRAFLO PUMP**
- Heavy Duty Hydraulic Motor Type
 - Impeller - 3 bladed axial - A36 Stainless Steel
 - Shaft material - 300 series stainless steel
 - High strength pump
 - Wear plates - A36 steel - upper and lower
 - Discharge 24" ANSI Pattern Flange
 - Hydraulic quick disconnects
 - Mechanical seal - Silicone carbide - Hydraulic-fluid bathed
 - Bearings - Hydraulic-fluid lubricated-50,000 hours - Minimum life.
 - Lightweight pump - approx 680 kg
 - Coating - MoTar Standard - Epoxy optional
- DIESEL Drive Unit**